

# Justification, Selection and Calculation of Technological Parameters of Equipment Kits of Mobile Crushing-Reloading-Conveyor Complexes

Annakulov T.J., Zairov Sh.Sh., Kuvondikov O.A.

Tashkent state technical university, Tashkent, Uzbekistan

**ABSTRACT:** A technique has been developed for selecting and calculating the technological parameters of sets of equipment for mobile crushing, reloading and conveyor complexes.

**KEYWORDS:** cyclic-flow technology, mobile complexes, transshipment complexes, mobile crushing plant, roller crusher, feeder bin, bunker capacity, inter-access loading crane, conveyor, productivity, parameters.

## I. INTRODUCTION

Nowadays, in the process of mining of minerals by the open method, cyclic-flow technology (CFT) is becoming more and more widespread, which makes it possible to significantly reduce the transportation distance of the rock mass due to the use of belt conveyors with tilt angles to 16-180, to reduce the cost of transportation of the rock mass by 30-40%, increase labor productivity 1.4-2 times. Intensive transition to the center of mineral extraction and mining of overburden is caused by the increase in transportation costs and the search for options for more efficient combined methods of delivering rock mass from deep horizons of quarries.

To increase the productivity of quarries, as well as reduce the cost of mining and transportation of rock mass, the problems of using CFT using mobile complexes are solved. There is a need to carry out scientific research on the development of methodologies for designing open pit mines using mobile crushing and reloading conveyor complexes (MCRCC), determining the degree of influence of geological, mining engineering and organizational factors on the open pit mine productivity, establishing dependencies on the productivity of MCRCC from the technological parameters of equipment included in the complex, justification of the field of application of technological complexes of open-pit mines MCRCC.

## II. RELATED WORK

The sequence of work MCRCC in CFT is as follows (Fig.1). The excavator loads the reloading into the crushing plant's bunker, then the reloading from the bunker enters the plate conveyor, and from there, through the feed bunker, into the two-roll crusher. Overburden through the discharge chute of the crusher enters the crusher discharge conveyor, which transports it to the mobile conveyor bridge and further to the bottomhole conveyor. Further transportation of the rock mass is carried out by the main conveyor with subsequent transshipment to the dump conveyor, from where the rock mass moves to the spreader, which forms internal dumps [1].

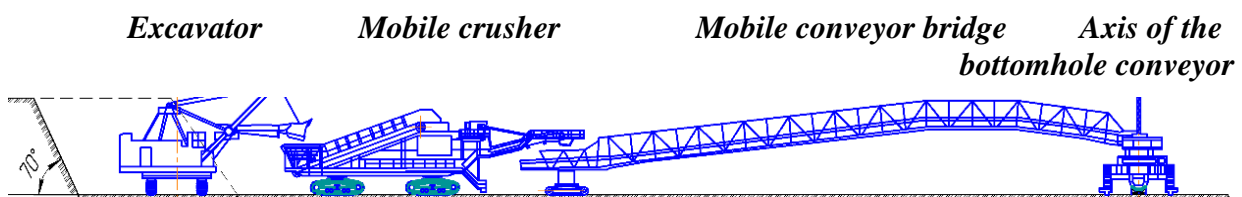

Fig. 1. Technological scheme for the development of overburden ledges CFT with MCRCC

Recently, the choice of the basic technological parameters of MCRCC with the use of mechanical excavators for specific operating conditions has become particularly relevant.

With the use of mobile crushers and conveyor transport, the costs of general production processes are reduced by 60% and they are more environmentally friendly [2]. In addition, it eliminates the need to install expensive equipment for ventilation of quarries, reduces energy consumption and metal intensity of the quarry by replacing numerous large trucks with a conveyor transport in the quarry, increases the level of automation of mining production and labor productivity, reduces production costs by reducing operating and capital costs.

Mobile crushing plants consist of an accumulation bunker, a crushing sector and a device for the continuous supply of rock to a conveyor belt. In the storage bunker, the rock is loaded with an excavator, wheel loader or other similar loading equipment.

In the crushing sector of mobile crushing plants, you can use various types of crushers, such as cone coarse crushers, jaw crushers, cone roller coarders, rotary co-rotation, rotary counter-rotation, two-roll, etc.

The most suitable for mobile crushing plants is the use of a two-roll crusher, the advantages of which include small dimensions in height, very high productivity and the absence of inertial loads on the undercarriage.

Companies “ThyssenKruppFurdertechnik”, PJSC “Novokramatorsk Machine Building Plant”, “TenovaTAKRAF”, “JoyGlobal”, “Metso” and “Kleemann” developed a CFT concept using fully mobile crushing plants. Innovation is the ability to move technology during mining, which achieves flexibility and mobility. In combination with continuously operating conveyor belts, transportation of dump trucks having been previously required is completely eliminated [3].

The use of continuously operating equipment in comparison with cyclically operating dump trucks allows you to increase productivity, save energy costs and reduce the negative impact on the environment.

The complex of CFT with fully mobile crushers includes a mechanical shovel type excavator, mobile crushing plant, mobile interloader loading crane, conveyor system.

The interaction of the elements of the MCRCC system is described by the functional model of the working processes: separation of the rock mass from the bottom and feeding it into the crusher - crushing - transfer of the crushed mass to conveyor systems. At the same time, the flow of rock mass determines the main parameters and characteristics of the MCRCC as a “input-process-output” system. The input can be represented by the following parameters: the estimated hourly productivity of the excavator, the intensity of the flow of goods, properties and particle size distribution of the incoming rock mass.

### III. OBJECTS AND METHODS OF RESEARCH

A process is a sequence of operations performed in the production cycle, in particular, in the MCRCC subsystems.

The main indicator of MCRCC, which characterizes its technical capabilities, is the estimated plant capacity for specific operating conditions.

The design capacity of the installation is determined by the productivity of the subsystems “bunker-feeder – mobile crusher and discharge conveyor - interloader reloader- bottomhole conveyor”.

When determining the MCRCC parameters, it is necessary to maintain the following relationship:

$$Q_E \leq Q_{B-F} \leq Q_{M.C} \leq Q_{D.C} \leq Q_{C.B} \leq Q_{B.C} \tag{1}$$

where-  $Q_E$ ,  $Q_{B-F}$ ,  $Q_{M.C}$ ,  $Q_{D.C}$ ,  $Q_{C.B}$ ,  $Q_{B.C}$  -respectively, the calculated productivity of the excavator, bunker-feeder, mobile crusher, discharge conveyor, mobile conveyor bridge and bottomhole conveyor, t/h.

The main parameters affecting the choice of equipment MCRCC for the development of rocks by these methods are given in Table.1.

**Table 1. Parameters affecting the choice of equipment MCRCC**

Equipment	Designation	Options
Excavator	$Q_E$ $V_B$ $t_C$	- productivity, t/h; - bucket capacity, m <sup>3</sup> ; - cycleduration, s <sup>-1</sup>
Bunker	$V_B$ $A$ $B_0$ $H_B$	- bunker capacity, m <sup>3</sup> ; - width of the upper part, mm; - width of the lower exhaust part, mm; - height, mm.
Feeder	$Q_{B-F}$	- productivity, t/h;

	$B_F$ $h_F$ $v_F$	- feeder web width, <b>mm</b> ; - height of the layer of rock mass, <b>mm</b> ; - webspeed, <b>m/s</b> .
Crusher (roll)	$Q_{M.C}$ $D_R$ $L_R$ $\beta$ $n_R$ $b_L$ $b_{OUT}$	- productivity, <b>t/h</b> ; - diameter of rolls, <b>mm</b> ; - roll length, <b>mm</b> ; - angle of capture of rolls, <b>degrees</b> ; - roll rotation frequency, <b>rpm</b> ; - size of the loading slot, <b>mm</b> ; - size of the outlet, <b>mm</b>
Crusher discharge conveyor	$Q_{D.C}$ $B_{D.C}$ $v_{D.C}$	- productivity, <b>t/h</b> ; - tape width, <b>mm</b> ; - tapespeed, <b>mm</b> .
Mobile conveyor bridge	$Q_{C.B}$ $B_{C.B}$ $v_{C.B}$	- productivity, <b>t/h</b> ; - tape width, <b>mm</b> ; - tapespeed, <b>mm</b> .
Bottomhole conveyor	$Q_{B.C}$ $B_{B.C}$ $v_{B.C}$	- productivity, <b>t/h</b> ; - tape width, <b>mm</b> ; - tapespeed, <b>mm</b> .

When choosing equipment of MCRCC taking into account the influence of the parameters specified in this table, it is necessary to guide the block diagram shown in Fig. 2

In this structural diagram, it is clear that the links of the MCRCC complexes are interconnected. For example, the volume of the bunker depends on the capacity of the excavator bucket and the maximum size of the piece of rock mass, and the width of the feeder web from the maximum size of the piece of rock mass and the productivity of the excavator. In general, the condition must be met according to the formula (1).

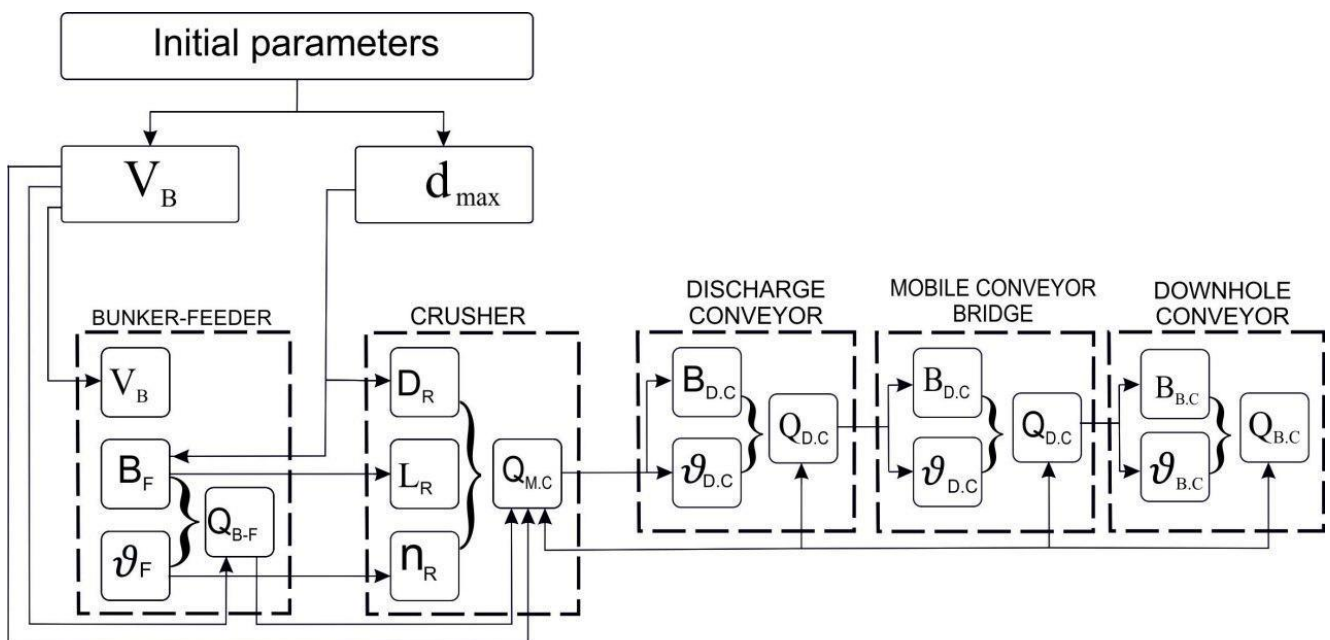

Fig.2. Structural diagram for determining the influencing parameters on the selection of the MCRCC subsystem

The theoretical productivity ( $m^3/h$ ) of the excavator is determined by the well-known formula:

$$Q_E = 60 \cdot V_B \cdot n_Z \tag{2}$$

where  $n_Z = 60/n_{cycle}$  cycle is a design-calculated number of cycles per minute;  $n_{cycle}$  - theoretical cycle time, min.

$$Q_E = 3600 \cdot V_B \cdot \frac{1}{n_{cycle}} \tag{3}$$

Technical productivity ( $m^3/h$ ) takes into account the working conditions of the excavator in the face and is the maximum possible for this model during continuous operation in specific conditions. Determined according to the expressions:

$$Q_E = 3600 \cdot V_B \cdot \frac{K_E}{n_{cycle}} \tag{4}$$

or

$$Q_E = 3600 \cdot V_B \cdot \gamma \cdot \frac{K_E}{n_{cycle}} \tag{5}$$

where  $K_E$  - the coefficient of excavation, which is the ratio of the filling ratio of the excavator bucket to the coefficient of loosening of the rock in the bucket.

When calculating the technical and operational productivity of an excavator, it is necessary to take into account the conditions of the face and the properties of rocks, including with varying degrees of preparation of rocks by the explosion, the presence of oversize, etc. Due to the fact that there are heterogeneous rocks in the face in terms of properties, productivity and  $K_E$  value, in case of their frequent change, it is necessary to take into account the fractional content of various rocks in the face and to find the weighted average values of the resistivity of the rocks for  $K_E$  digging, the cycle time of the excavator  $t_c$ , as well as the coefficient and the quality of slaughter.

The main requirements that characterize the operation of the bunker device include: the required geometric (technological) volume of the bunker, its capacity, the size of the outlets, the requirements for the construction of the "bunker-feeder" system.

In mobile crushing plants, an open-type bunker-feeder is used, which is mounted with a plate feeder. Most bunkers, the hoppers of mobile crushers in combination with feeders are made in the form of an inverted obelisk. The volume of the bunker depends on the capacity of the excavator's bucket, which is unloaded. The capacity of the bunker depends on the geometric dimensions of the accompanying elements (excavator bucket, feeder width) and the maximum dimensions of the feed material.

According to the condition of ensuring the normal extraction of incoming goods from the bunker, the width of the feeder is determined from the expression [4]:

$$B_F = 1,65 \cdot d_{max} \tag{6}$$

where  $d_{max}$  is the maximum size of a piece of rock, m.

The width of the feeder determines the width of the lower outlet of the bunker, taking into account the design features of the accompanying elements.

When installing the feeder under the bunker, the width of the lower outlet part of the bunker is determined by the formula:

$$B_0 = B_F - 2(b + \Delta b) \tag{7}$$

where  $b$  is the wall thickness of the bunker with casings, mm;  $\Delta b$  is the gap between the walls of the bunker and the guide blades of the feeder, mm.

The geometric size of the upper part of the bunker is determined by the formula [5]:

$$A \geq (1,7 - 1,8) \sqrt[3]{V_B} \tag{8}$$

This value is checked by the condition of the reaction time of the driver when stopping and turning for unloading. The reaction time of the driver is 0,5-0,8 sek.

The angle of rotation of the handle of this period is

$$\Delta\beta = \frac{\beta}{t_{rot.}} \cdot t_{reac.} \tag{9}$$

where  $t_{rot.}$  is the rotation time by  $\beta$  degrees, s.

Then the path of braking in the period  $t_{reac.}$  will be

$$\Delta l = \frac{\pi R_r}{180} \cdot \Delta\beta \tag{10}$$

The width of the upper part of the bunker is limited by the condition

$$A \geq B_b + \Delta l \tag{11}$$

here  $B_b$  is the excavator bucket width.

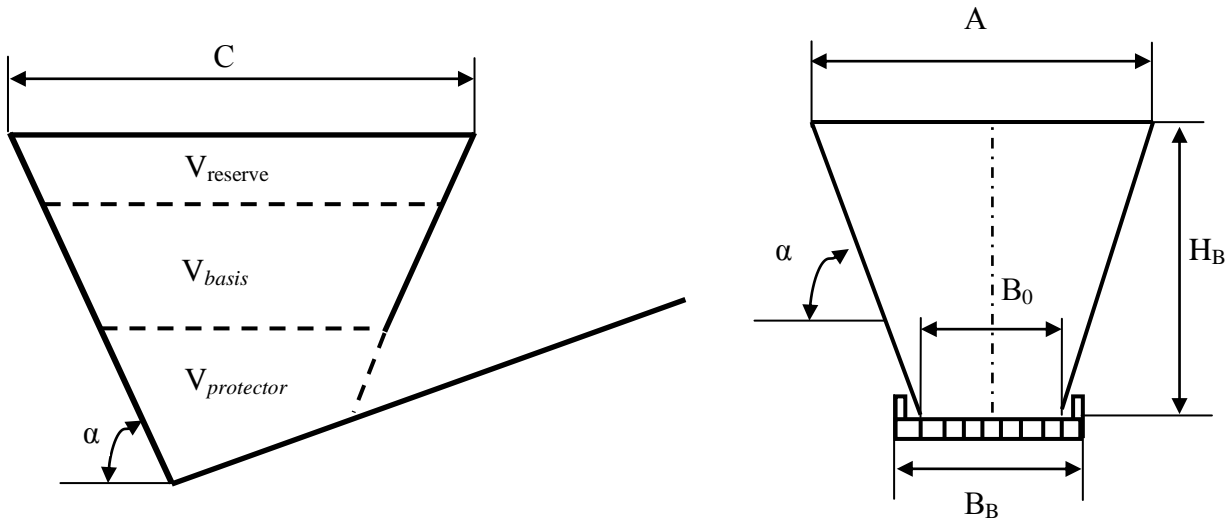

Fig.3. Scheme for the calculation of the bunker feeder mobile crusher

The maximum height of the bunker for mobile crushers is determined by the formula:

$$H_B = (0,8 \cdot H_p - e) - h_{s,s} \tag{12}$$

where  $H_p$  is the maximum height of the excavator unloading, m;  $e$  - is the reserve between the bucket and the bunker, m;  $h_{s,s}$  is the height of the support structure where the feed hopper is installed, m.

The length of the upper part of the bunker is determined by the formula [6]:

$$C = 2H_B \text{ctg}\alpha + 0,75B_0. \tag{13}$$

Based on the above geometrical parameters and the shape dependence of the shape, the capacity of the bunker can be determined:

- international standards (GOST ISO21873-1-2013);
- on the specific form of the bunker.

The total geometric volume of the mobile crusher is divided into the following parts

$$V_B = V_{safety} + V_{basic} + V_{spare} \tag{14}$$

where  $V_{safety}$  is the safety volume of the hopper.

$V_{basic}$  - basic volume required for the reception of the gorse mass;

$V_{spare}$  - spare volume, characterized by the unevenness of the equipment.

The safety volume is determined depending on the shape of the bunker, type of feeder, its installation coal, the size of the feeder in the bunker, the required thickness of the protective layer on the feeder and the height of the installation of the metering controller of the output part of the bunker.

The main volume of the bunker is assumed to be equal to the capacity of the excavator bucket.

The reserve volume of the bunker is taken within 20-30% of the total volume of the bunker [6].

The productivity of the hopper feeder with a known width is determined by the formula:

$$Q_{B-F} = 3600B_F h_F v_F \gamma \varphi, \tag{15}$$

where  $v_F$  - the rate of extraction of the rock mass from the bunker by the feeder;  $B_F$  - width of the outlet of the bunker, m;  $h_F$  - height of the layer of rock mass extracted from the bunker, m;  $\gamma$  - bulk density of the rock mass;  $\varphi$  is the coefficient of uniformity of release.

#### IV. RESULTS OF THE RESEARCH

MCRCC can include several conveyors: crusher feed conveyor, interstitial loading crane conveyor, downhole conveyor and general transfer conveyor for parallel lines. All conveyors installed in one sequential system transport the crushed mass of a mobile crusher.

The required estimated hourly productivity ( $\text{m}^3/\text{h}$ ) of the accompanying conveyors in the complex is determined from the expression:

$$Q_{i,K} = k_{u,p} Q_{M.C} \tag{16}$$

where  $k_{u,p}$  - the coefficient of unevenness of the feeder ( $k_{u,p} = 1,05-1,1$ ).

The parameters of the conveyor, characterizing the productivity, include the width and speed of the tape. With known estimated productivity  $Q_{M.C.}(M)$ , and the selected belt speed, the required width of the conveyor belt is determined from the expression:

$$B_{i,K} = 1,1 \left( \sqrt{\frac{Q_{i,K}}{k_{ce} K_p v \gamma}} + 0,05 \right) \tag{17}$$

where  $k_{ce}$  - coefficient characterizing the operating conditions of the conveyor (accepted for stationary installation  $k_{ce} = 1,0$ , for bottomhole and semi-stationary  $k_{ce} = 0,88 - 0,9$ );  $K_p$  - productivity factor;  $v$  - the speed of the conveyor belt (selected depending on its productivity and width, the type of cargo and the design of roller bearings. Considering the work of loading and reloading points, usually inside the transport system, the speed should not be more than 6,5 m/sec. When transporting rocky rocks and ores - 2,0; 2,5; 3,15 m/sec, during transportation of coal, loose overburden - 3,15; 4,0; 5,0 m/s; for conveyors with suspended roller supports during transportation of overburden, take 5,0; 5,5 m/s).

The value of the calculated width of the tape from the condition of lumpiness of the transported cargo for open cast mining, containing large pieces up to 15% by weight, is recommended to take:

$$B_{i,K} \geq (2,3 \div 2,5) d_{max} \tag{18}$$

From the two values obtained B is chosen the greatest.

Let us consider the main parameters of the crushing sector of the mobile crusher according to the well-known method. The relations for calculating the basic parameters of roll crushers are width, length, angle of capture, speed of rotation of rolls and productivity.

The angle of capture in roller crushers is the angle  $\beta$  between two tangents to the surface of the rolls at the points of contact with the material being crushed (Fig. 4). A piece of material will be captured if the condition  $\beta \leq 2\phi$  or  $\alpha \leq \phi$  is met.

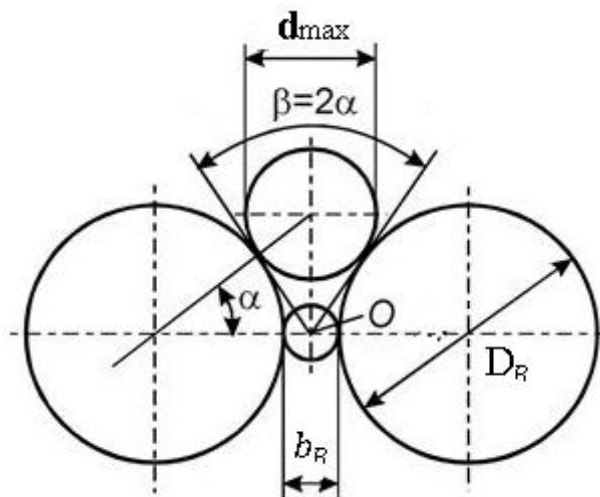

**Fig.4. Settlement scheme of shaft crusher**

The angle of capture at the shaft crushers for normal crushing should not exceed the double angle of friction. With the friction coefficient for real cases  $f = 0,30-0,45$ , the angle of friction is  $\phi = 16040' \div 24020'$ . In practice, for smooth rolls take  $\alpha = 16 \div 240$ , to exclude the extrusion of crushable pieces from the working area. Toothed and grooved rolls provide better gripping conditions, therefore  $\alpha = 20-300$ .

The diameter of the roll condition of the incoming maximum sizes  $d_{max}$  pieces can be determined by the formula [7]:

$$D_B = \frac{d_{max} k - b_R}{1 - k} \tag{19}$$



where  $k$  is the coefficient of capture (for smooth rolls,  $k = 0,954$ , for corrugated  $k = 0,92$ ;  $b_R$  is the width of the exit slit, m.

The frequency of rotation of the rolls crusher should not exceed a certain value at which unstable conditions of material capture are created and undesirable fluctuations of loads occur.

The most favorable mode of operation occurs when the peripheral speed of the rolls  $\omega_{opt} = 3-6$  m/s. From here is the speed of the rolls [7]:

$$n_{opt.} = \omega_{opt.} / (\pi D_R) \quad (20)$$

The maximum possible frequency of rotation of the rolls is determined by the formula proposed by prof. L.B. Levenson:

$$n_{max} \leq 102,5 \sqrt{\frac{f}{\rho d D_R}} \quad (21)$$

where  $f$  is the coefficient of friction of the material on the rolls (for strong rocks  $f > 0,3$  for clays  $f < 0,45$ );  $d$  - diameter of the piece of the source material, m;  $\rho$  is the density of the material being ground,  $kg / m^3$ .

The length of the rolls is determined by the condition of ensuring the productivity of the feeder  $Q_P$  or incoming goods with a known roll diameter  $D_R$  and the rotation frequency of the rolls  $n_R$ . The productivity of the feeder  $Q_F$  is equalized with the productivity of the crusher  $Q_C$  by condition (1).

The productivity of the crusher with the frequency of rotation

$$Q_C = 1,25 \pi D_R L_R b_R n_R \mu \quad (22)$$

where 1.25 - coefficient taking into account the possible divergence of the rolls during operation;  $\mu$  is the coefficient taking into account the degree of loosening of the material (for durable materials,  $\mu = 0,2-0,3$ , for wet materials,  $\mu = 0,4-0,6$ ).

From the formula (21) can determine the length of the rolls:

$$L_R = Q_R / 1,25 \pi D_R b_R n_R \mu \quad (23)$$

## V. CONCLUSION

Thus, a method has been developed for calculating the technological parameters of sets of equipment for mobile crushing, reloading and conveyor complexes.

## REFERENCES

- [1] Annakulov T.J. Improvement of cyclic-flow technology for the development of overburden in the Angrenskiy section using mobile complexes. "European Applied Sciences" ORT Publishing. - Stuttgart, Germany, 2015. - # 6. 58 ÷ 60 p.
- [2] Jiganov P.A. Dissertation: Increase of efficiency of functioning of career crushing and reloading installations / thesis Candidate of Technical Sciences - Ekaterinburg, 2009. - 219 p.
- [3] Yasyuchenya S.V., Opanasenko P.I., Isaichenkov A.B., Rybak L.V., Burtsev S.V., Minibaev R.R., Suprun V.I., Pastihin D.V., Radchenko S.A., Pereygin V.V., Levchenko Ya.V. Problems and prospects of cyclic-flow technology in the open development of coal and ore deposits // Rational exploitation of the subsoil [electronic resource]: Scientific, technical and methodical journal. - M.: Scientific Information Publishing Center "Nedra-XXI", 2014. - Number 3. - pp. 52-60.
- [4] Vasiliev M.V. Transportation deep quarries. - M.: Nedra, 1983. - 197 p.
- [5] Rjevsky V.V. Open pit mining. Book 1: Production Processes. - M.: Izd. URSS, 2019. - 341 p.
- [6] Yudin A.V. Transloading systems of combined transport. Technical solutions and the choice of parameters: A manual with applications. Ekaterinburg, ed. Ural State Mountain Geological Academy, 1993. - 116 s.
- [7] Lagunova Yu.A. Designing processing machines: a textbook. Ural State Mining University. - Ekaterinburg: Publishing house of the USU, 2009. - 378 p.



ISSN: 2350-0328

**International Journal of Advanced Research in Science,  
Engineering and Technology**

**Vol. 6, Issue 2, February 2019**

**AUTHOR'S BIOGRAPHY**

	<p><b>Annakulov Tulkin Jovbekovich</b></p> <p>Senior lecturer of the Department of Mining electromechanics of Tashkent state technical University after name I.A. Karimov <b>Address:</b> Tashkent, Universitet street-2</p>
	<p><b>Zairov Sherzod Sharipovich</b></p> <p>Deputy Dean of the Mining Faculty of the Navoi Mining Institute, Ph.D., associate professor. <b>Address:</b> Navoi, Galaba-2 street</p>
	<p><b>Kuvandikov Oybek Abdimurodovich</b></p> <p>Senior lecturer of the Department of Mining electromechanics of Tashkent state technical University after name I.A. Karimov <b>Address:</b> Tashkent, Universitet street-2</p>