



ISSN: 2350-0328

**International Journal of Advanced Research in Science,  
Engineering and Technology**

**Vol. 7, Issue 5, May 2020**

# **Theoretical study of the separation process of soybean seed from bean-pod under influence of rickers**

**Abduqodir Rosaboev, Obid Pardaev**

PhD, Senior Researcher, Scientific Research Institute of Agricultural Mechanization, Yangiyul district, Uzbekistan  
Researcher, Scientific Research Institute of Agricultural Mechanization, Yangiyul district, Uzbekistan

**ABSTRACT:** The article provides information on theoretical study of the separation process of soybeans from bean-pods under influence of device rickers that separates soybeans from pods. The results of theoretical studies show that in order to separate soybean seeds from their pods, maximum value of impact force acting on them must be around  $\max = 7.9 \text{ N}$ .

**KEYWORDS:** soybean stem, soybean seed, pod, separation, device, screw shaft, peg, impact force, deformation, seed separation from pods, moment of force, moment of inertia.

## **I. INTRODUCTION**

It is known that today, in order to separate the seeds of agricultural crops from corn and legumes, complex, high-productivity and powerful combines are used. These combines are able to harvest the crop quickly and with high quality, and their use on seed farms is not economically justified. With this in mind, in recent years, due to the establishment of farmers and farms in agriculture, there is a need for energy and resource-saving devices to separate the seeds of agricultural crops from legumes in order to properly organize the work of seeding. This is because each farm will be able to produce required amount of seeds from seeds of cultivated agricultural crops, depending on their needs. Therefore, the development and substantiation parameters of energy and resource-saving device for the separation of agricultural crops seeds from cobs and legumes, which meet the needs of farmers and farms, is very relevant and of great importance for the national economy.

## **II. BACKGROUND OR RELATED WORK**

In foreign countries, including Russia, certain amount of research has been carried out on development of devices that separate the seeds from cobs and pods, as well as to substantiate their constructive dimensions and modes of operation [1,2]. However, structure of devices developed by them is compound, and insufficient research has been done to theoretically substantiate the separation of seeds from cobs and pods under influence of piles in the technological process of seeds separation from agricultural crops.

Theoretical substantiation of the separating process soybean seed from the pods without damaging it by interaction of the device with rickers attached to the shaft in the form of screws.

## **III. MATERIALS AND METHODS**

In the theoretical study of separation process of soybean seeds from the pods with rickers attached to the shaft of the device in form of screws, it was carried out on the basis of mathematical analysis using laws and rules of theoretical mechanics.

## **IV. ANALYSIS AND RESULTS**

As a result of patent research, preliminary theoretical and experimental research, special device was developed to separate soybeans seed from legumes [3,4,5,6]. Figure 1 shows schematic diagram of device designed to separate soybean seed from pods.

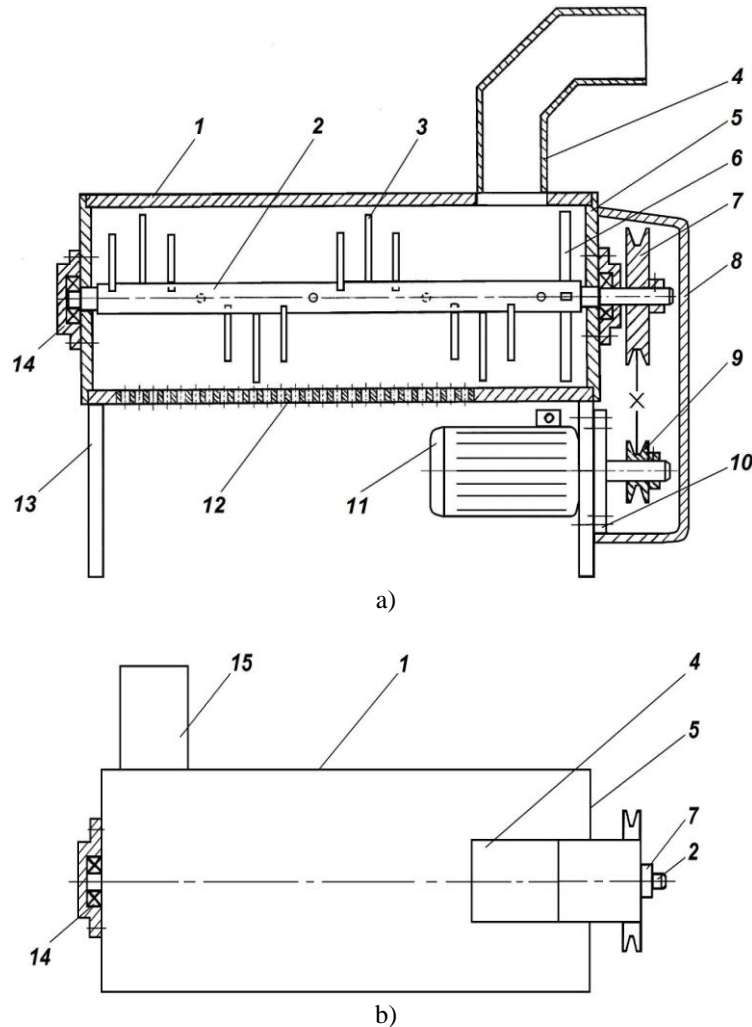

a) side view; b) view from above

1-cylinder; 2-shaft; 3-rickers; 4-loading bunker; 5-flanges; 6-fan; 7 and 9-pulleys; 8-protection device; 10-basis; 11-electric motor; 12-sieve; 13-framework; 14-bearings; 15-output window

Fig. 1. Schematic diagram of the device that separates soybean seeds from pods

The device consists of hollow cylinder 1, shaft 2, rickers 3, loading bunker 4, flanges 5, fan 6, pulleys 7 and 9, protection device 8, basis 10, electric motor 11, sieve 12, framework 13, bearings 14 and output window 15.

Inside the hollow cylinder 1 is mounted shaft 2 with help of flanges 5 and bearings 14, to which are fastened in the form of screws 3 at a certain distance from each other and at an angle. A fan 6 is attached to the front of shaft 2 to create airflow.

A certain distance is left to the right of the fan 6, and upper part of the hollow cylinder 1 is equipped with loading bunker 4. At its bottom, a sieve 12 is mounted, leaving certain distance from the straight of loading bunker. A special window 15 is opened on opposite side of the end section to expel the crushed sob and stem pieces from inside the hollow cylinder 1.

The principle of operation of the device is as follows. When it is connected to the mains, electric motor 11 and pulleys 7 and 9 are driven by a belt drive in the form of screw 3 fastened shaft 2. At this time the seeds of agricultural crop are loaded into loading bunker 4 with stems and pods. When the seeds of crops' fall into the hollow cylinder 2 from loading bunker 4 with the stalks and pods, the rickers 3 hit them and separate the seeds from pods. The rickers 3 not only separate the seeds from pods under influence of impact, but also push them forward in direction of the shaft 2 rotation, as they are fastened in the form of screw. The seeds left in the pods are completely separated as a result of the

other rickers 3 hitting in the direction of movement and being pushed forward. Pieces of crushed stems and pods are thrown out through a special window 15 on the opposite side of the hollow cylinder 1. The seeds separated from the pods are sent for placement in bags through the sieve 12 in the direction of movement and under influence of the air flow generated by the fan 6. In this way, the technological process of separating the seeds of agricultural crops from legumes continues uninterrupted.

Preliminary experimental studies on seeds separation of agricultural crops from legumes have yielded positive results. It should be noted that the eyes of the sieve 10 mounted on the bottom of hollow cylinder 1 can be separated from cobs and pods of all types of agricultural crops by replacing eyes of the sieve with mesh of desired diameter according to the geometric dimensions of seeds.

In process of technological operation of the device, it is important to study interaction of the rickers 3 attached to the shaft 2 in the form of screw with pods in order to separate soybean seed from ears and pods. Therefore, we theoretically study the process of seeds separation from them under influence of impact force  $F_3$  applied to the pods by rickers. Under influence of impact force, soybean seeds undergo compression and elongation deformations.

Figure 2 shows a diagram of the interaction of soybean seed with a ricker.

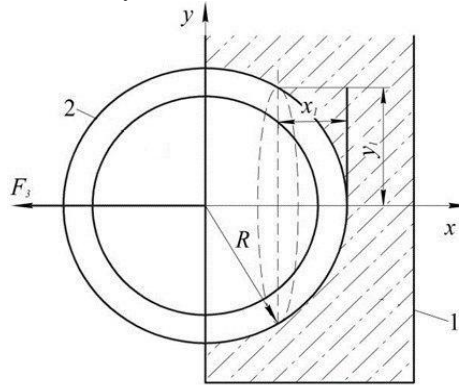

Fig. 2. Interaction Scheme of ricker and soybean legume: 1-ricker; 2-soybean legume

As can be seen from the diagram shown in Figure 2, under influence of impact force  $F_3$ , the compression of soybean legume 2 relative to the axis  $x$  and elongation deformation relative to the axis  $y$  occur. The separation of soybeans from pods under the influence of deformation depends on its compression or elongation. To confirm this, we use equation of relationship between the moment of force and moment of inertia of the impact force  $F_3$  acting on legumes by rickers [7].

$$\frac{EJ(y_1)dx_1^2}{dy_1^2} = M(y_1). \quad (1)$$

where  $E$  - modulus of elasticity, Pa;  $M(y_1)$  - compressive moment under influence of impact force,  $N \cdot m$ ;  $J(y_1)$  - moment of inertia,  $kg \cdot m^2$ .

If the moment of force relative to the axis  $Y$  is equal to  $M(y_1) = -F_3 y_1$ , the moment of inertia is equal to

$$Y(y_1) = \frac{\pi Z^4}{4}, \quad (2)$$

For theoretical and mathematical analysis of the moment of inertia we use the scheme described in Figure 3 [7,8]

Using Figure 3, we get sphere equation

$$z^2 + (R - y_1)^2 = R^2. \quad (3)$$

If we solve expression (3) in relation to  $z$  and put it in equation (2), we get following expression

$$J(y_1) = \frac{\pi}{4} y_1^2 (2R - y_1)^2. \quad (4)$$

where  $R$  - average radius of soybean legume, m.

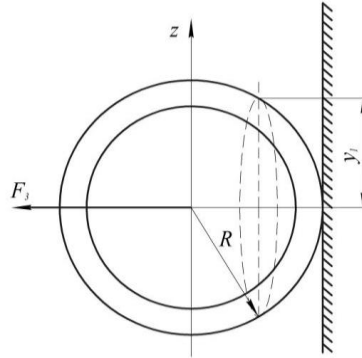

Fig. 3. Calculation Scheme for the moment of inertia

Substituting expression (4) into expression (1), we obtain following equation

$$F_3 y_1 = \frac{E \frac{\pi}{4} y_1^2 (2R - y_1)^2 dx^2}{dy_1^2} \tag{5}$$

Solving expression (5) in relation to  $\frac{dx_1^2}{dy_1^2}$ , we obtain following equation

$$\frac{dx_1^2}{dy_1^2} = \frac{4F_3}{\pi E y_1 (2R - y_1)^2} \tag{6}$$

Integrating expression (6) once, we obtain following equation

$$\frac{dx_1}{dy_1} = \frac{4F_3}{\pi E} \int \frac{dy}{y_1 (2R - y_1)^2} + C \tag{7}$$

or

$$\frac{dx_1}{dy_1} = \frac{F_3}{\pi E} \left[ \frac{1}{R^2} \ln \frac{2R - y_1}{y_1} - \frac{2}{R(2R - y_1)} \right] + C \tag{8}$$

$x_1$  in expression (8) is equal to the following

$$x_1 = \frac{F_3}{\pi E} \left[ \frac{1}{R\pi^2} \int \ln \frac{2R - y_1}{y_1} dy_1 - \frac{2}{R} \int \frac{dy_1}{2R - y_1} \right] + C y_1 + D \tag{9}$$

Based on the initial conditions  $C$  and  $D$  are invariant, we determine their value under following conditions: and  $x_1 = R$ ,

$$\frac{dx}{dy_1} = 0 \text{ and } y_1 = 0.$$

If so  $x_1 = R$ , the value of  $C$  in (9) is as follows

$$C = \frac{2F_3}{\pi ER^2} \tag{10}$$

Substituting this expression for (9) gives the following expression

$$x_1 = \frac{F_3}{\pi ER} \left[ 2 - \frac{(2R - y_1) \ln(2R - y_1)}{R} - \frac{y_1 \ln y_1}{R} + 2 \ln(2R - y_1) \right] + \left( \frac{2F_3}{\pi ER^2} \right) y_1 + D \tag{11}$$

we determine the value of  $D$  using the equation  $x_1 = R$  and  $y_1 = 0$

$$D = -\frac{4F_3}{\pi ER} \tag{12}$$

Substituting this expression into expression (11), we form following expression



$$x_1 = \frac{F_3}{\pi ER} \left[ 2 - \frac{(2R - y_1) \ln(2R - y_1)}{R} - \frac{y_1 \ln y_1}{R} + 2 \ln(2R - y_1) \right] + \left( \frac{2F_3}{\pi ER^2} \right) y_1 - \frac{4F_3}{\pi ER}. \quad (13)$$

The expressions (13) shows that the force of impact on soybean legume by the rickers causes legume to be compressed in width and elongated in length. In general, the impact strength depends on modulus of elasticity in the process of separating soybean seed from pods.

If the maximum impact force expended by rickers to separate soybean seeds from pods is used to compress them across the width, i.e.  $y_1 = 0$ , the expression (13) will be as follows.

$$x_{1max} = -\frac{2F_3}{\pi ER}. \quad (14)$$

The expression (14) shows that based on the physical and mechanical properties of legume soybeans, its deformation  $x_{1max} = 1.8$  mm and  $E = 0.62$  MPa and  $R = 4.5$  mm, maximum impact force to separate soybean seeds from pods value  $F_3 = 7.9$  N.

If the value of impact force decreases from this value, soybean seeds will not be separated from pods, and if it increases, the degree of damage to the isolated soybean seeds will increase.

#### IV. CONCLUSIONS

Separation of soybean seeds without damage under influence of rickers fastened to the shaft of device in the form of screws is achieved when the value of the modulus of elasticity  $E = 0.62$  MPa, average radius of the legume soybean  $R = 4.5$  mm, the deformation of the legume  $x_{1max} = 1.8$  mm and maximum value of the impact force  $F_3 = 7.9$  N.

#### REFERENCES

1. Shastalka selection SHS-0,1 and shastalka selection for seed-growing ShSS-0,5. Guide to the mechanization of selection and seed production. Moscow, VIM, pp. 108-113, 1978.
2. Khegay P.A., Gubanov A.A., Ma S.A., Shaxmuradyan S.M., Polyakov A.G., Ovchinnikov N.I. (1986): A device for removing pericarp in seeds. Russian patent No. 1250209. Official newsletter 30, 1986.
3. Rosaboev A.T., Egamnazarov G.G., Yuldoshev O.K., Pardaev O.R. A device for separating seeds of agricultural crops. International scientific journal "Young Scientist". Moscow, No. 7.2 (111.2). pp. 70-72, 2016.
4. Rosaboev A., Pardaev O. Improving the device for seeds separating of agricultural crops. AGRO ILM. Tashkent, № 5, p. 97, 2017.
5. Pardaev O.R. The results of the development of a device for seeds separating from stalks and stems. Current problems and development trends of modern research, innovations, techniques and technologies: Materials of the Republican scientific-technical conference. Jizzakh, pp. 86-88, 2018.
6. Rosaboev A.T., Pardaev O.R. Substantiation of output width of the loading bunker of the device that separates soybean seeds from pods. Science and education. Tashkent, April, pp. 220-226, 2020.
7. Shabelsky V.E. Technology and means of mechanization of the soybean seed shell removal process: Diss. ... can. tech. sciences. Blagoveshchensk, p. 43, 2003.
8. Belyaev N.M. Resistance of materials reprocessing. Moscow, Science, ed. 15th, p. 608, 1976.